

TYPE 1
SINGLE RESIDENTIAL

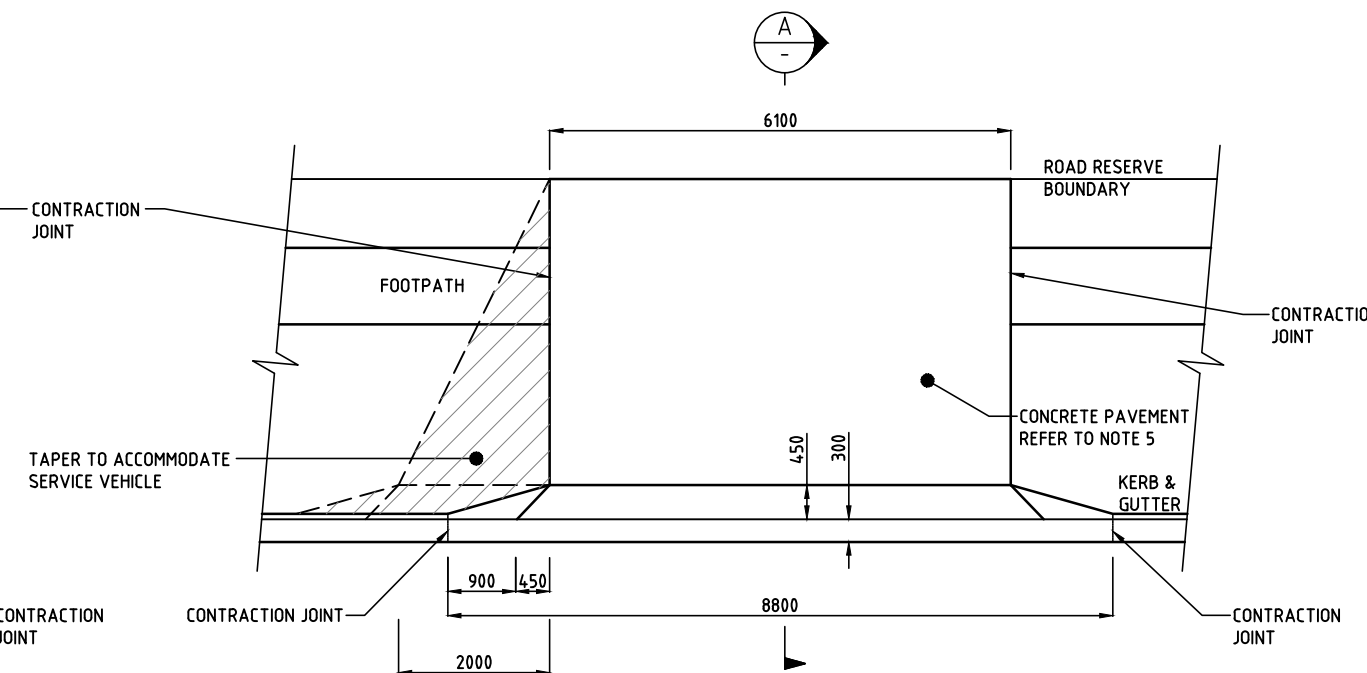

TYPE 2
INDUSTRIAL COMMERCIAL AND DOUBLE RESIDENTIAL

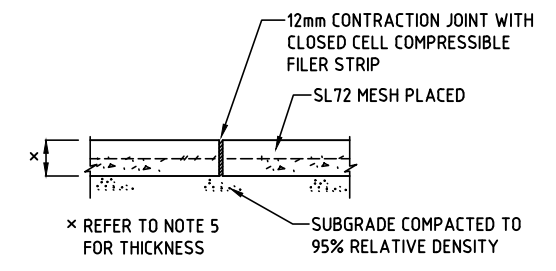

EXPANSION JOINT

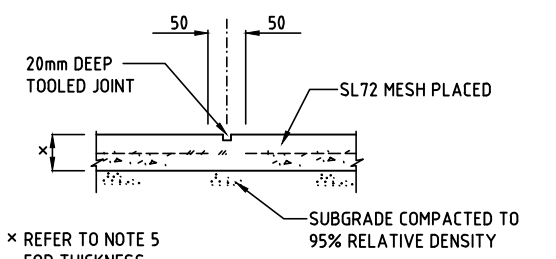

TOOLED JOINT

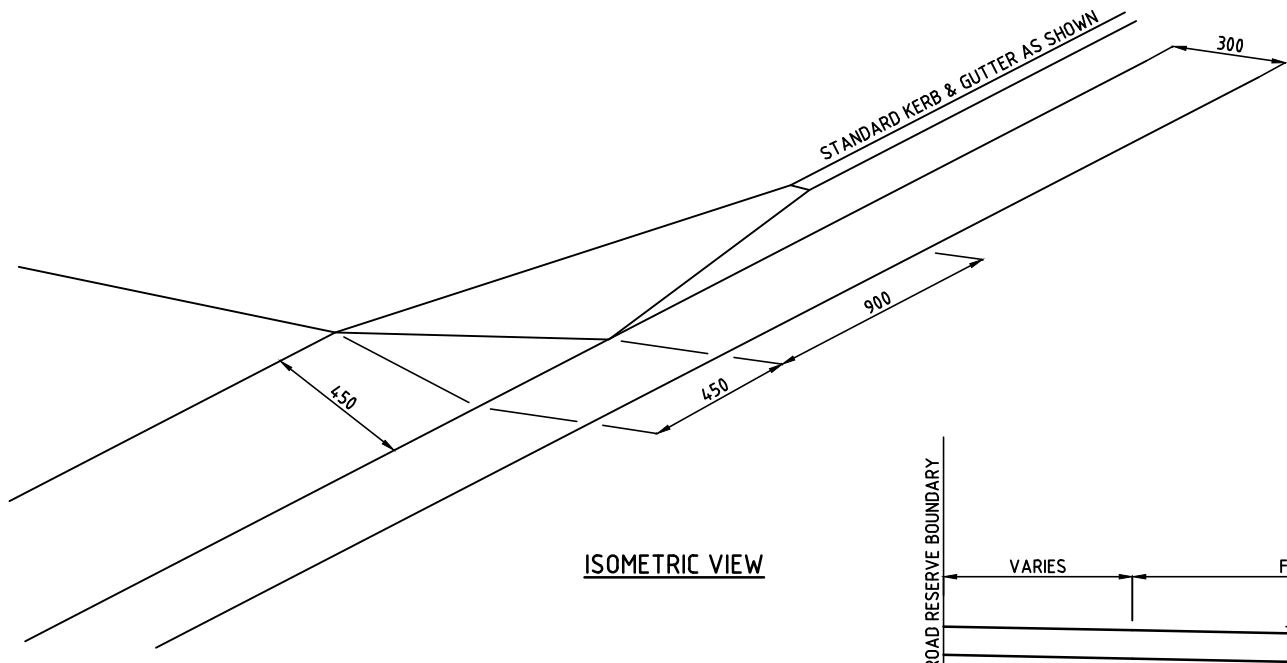

ISOMETRIC VIEW

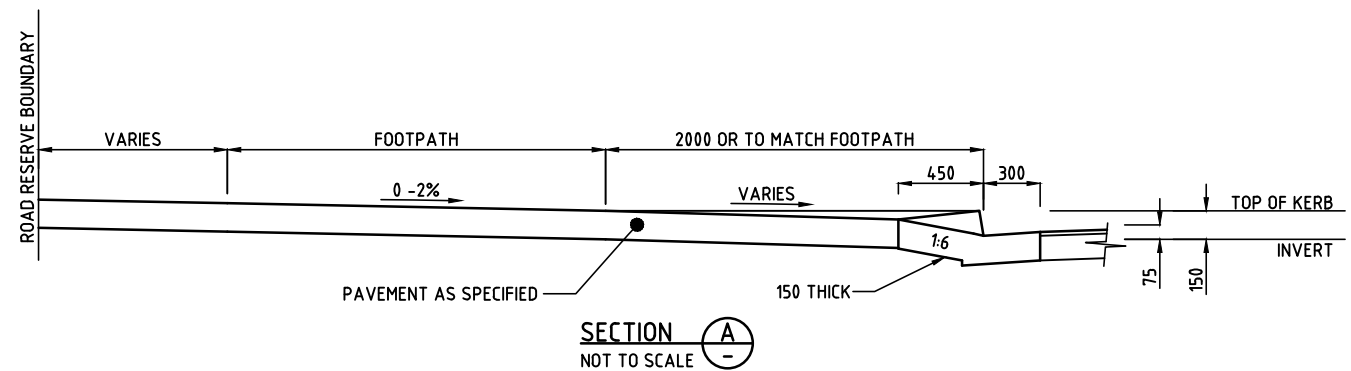

SECTION A-A
NOT TO SCALE

GENERAL NOTES:

- ALL DIMENSIONS IN MILLIMETRES UNLESS NOTED OTHERWISE.
- COMPACT SUBGRADE TO A DEPTH OF 150mm AT 95% RELATIVE DENSITY.
- USE N25 CONCRETE TO AS 1379-2007 AND AS 3600-2009. MOIST CURE FOR A MINIMUM OF 48 HOURS. DRIVEWAYS NOT TO BE USED DURING THIS PERIOD.
- PROVIDE BROOM FINISH TO ALL RAMP SURFACES.
- CONCRETE PAVEMENT THICKNESS SHALL BE IN ACCORDANCE WITH:
 - A - TYPE 1: SINGLE RESIDENTIAL VEHICLE ACCESS: 100mm THICK PAVEMENT, SL72 REINFORCEMENT PLACED CENTRALLY.
 - B - TYPE 2: INDUSTRIAL/ COMMERCIAL OR DOUBLE VEHICLE ACCESS: 150mm THICK PAVEMENT SL72 REINFORCEMENT PLACED CENTRALLY.
- MATCH NEW DRIVEWAYS TO EXISTING FOOTPATH.
- ANY MODIFICATION TO THE DETAILS SHOWN WILL REQUIRE FORMAL APPROVAL BY THE DEPARTMENT.
- CONCRETE JOINTS:**
 - A - PROVIDE CONSTRUCTION JOINTS AT 4m MAXIMUM CENTRES ROUGHEN AND CLEAN FACE OF HARDENED CONCRETE. REMOVE SOFT MATERIAL, FOREIGN MATTER AND LAITANCE.
 - B - PROVIDE EXPANSION/ CONTRACTION JOINTS AT 12m MAXIMUM CENTRES AND AT ALL JUNCTIONS WITH EXISTING STRUCTURES.
 - C - PROVIDE TOOLED JOINTS AT 2.5m CENTRES, WITH 20mm DEEP JOINTING TOOL. JOINTS TO BE PERPENDICULAR TO EDGE OF CONCRETE PAVEMENT SLAB.
- ACCESSES TO CATER FOR LARGE VEHICLES WILL REQUIRE INDEPENDENT DESIGN, AND BE SUBMITTED TO THE DEPARTMENT FOR APPROVAL PRIOR TO CONSTRUCTION.

No.	DESCRIPTION	DATE	NAME	DEPT./COMPANY
0	ISSUED AS A STANDARD DRAWING	SEPT 2017	J.LEESON	EES/DIPL
AMENDMENTS				

WARNING
BEWARE OF UNDERGROUND SERVICES. THE LOCATIONS OF UNDERGROUND SERVICES ARE APPROXIMATE ONLY AND THEIR EXACT POSITION SHOULD BE PROVEN ON SITE. NO GUARANTEE IS GIVEN THAT ALL EXISTING SERVICES ARE SHOWN.

DRAWN J.LEESON DATE JUNE 2017	CHECKED S.HATZI DATE JUNE 2017
DESIGNED S.DAVIS DATE JUNE 200	CHECKED
DESIGN LEADER S.HATZI DATE 1/09/2017	DESIGN DIRECTOR S.JACKSON DATE 1/09/2017



STANDARD DRAWINGS KERBING, FENCING & LANDSCAPING				
URBAN SINGLE & DOUBLE PROPERTY ACCESSES				
FILE No.	ASSET No.	SHEET No.	DRAWING No.	AMEND.
-	-	1 OF 1	CS3301	0
				SHEET SIZE A1