

SOIL TYPE (REFER SPEC.)	PILE DEPTH H	VOLUME OF CONCRETE (m3)
SOFT CLAY OR VERY LOOSE SAND	2.2	0.6
COMPACT TO MEDIUM SAND	1.8	0.5
FIRM TO STIFF CLAY OR SANDY CLAY	1.4	0.4
NON STANDARD	TO BE SPECIFIED	N/A

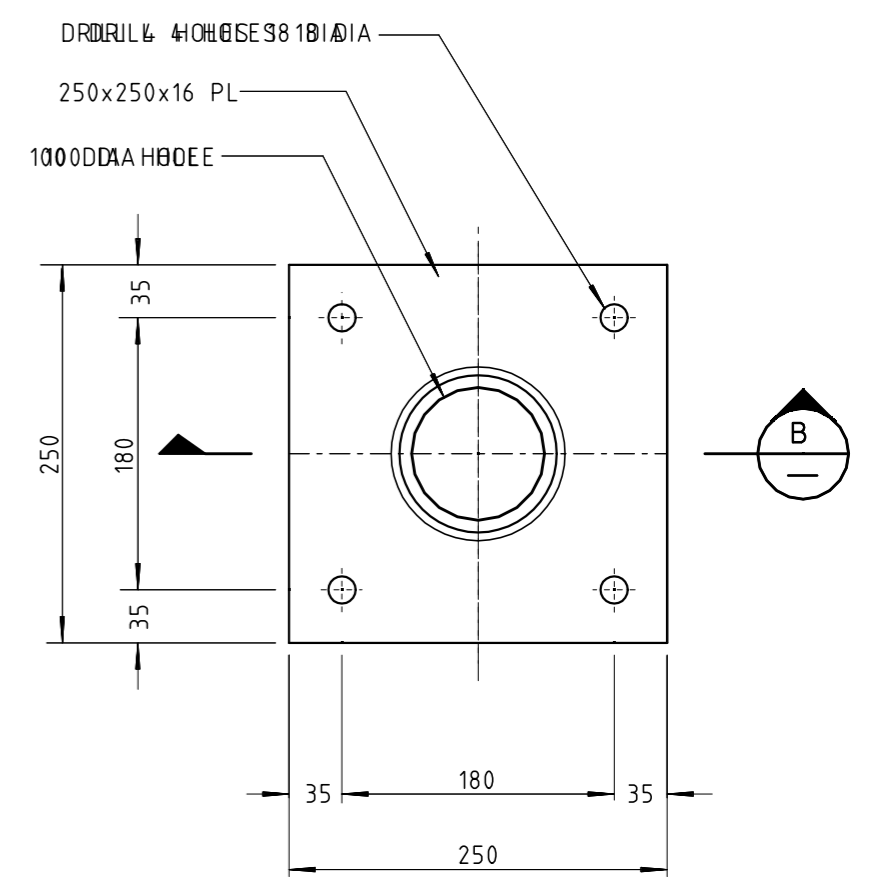
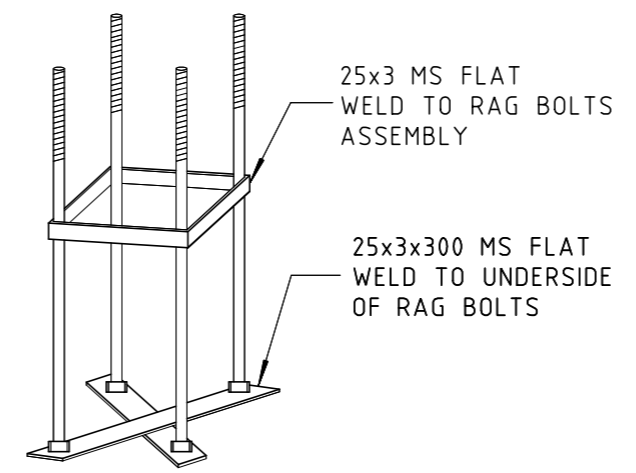
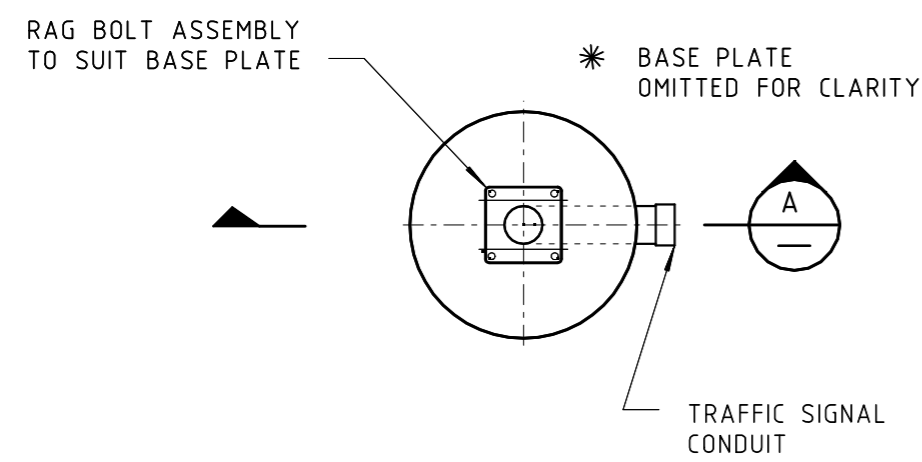
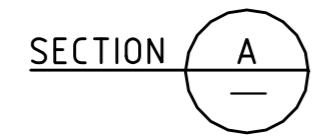

- NOTES
- USE CONCRETE STRENGTH GRADE N25.
 - USE GRADE 4.6 BOLTS AND NUTS.

15/03/2010 3:54:02 PM X:\CIVIL STANDARD DRAWINGS\TRAFFIC 6 - CS1500 SERIES STANDARDS\CS1501-3.dgn

No.	DESCRIPTION	DATE	INIT.
3.	GOVERNMENT DEPARTMENT LOGO CHANGED.	3/2010	W.L.
2.	NOTES UPDATED.	7/2004	K.S.
1.	GOVERNMENT DEPARTMENT LOGO CHANGED.	5/2002	K.S.

WARNING
BEWARE OF UNDERGROUND SERVICES

The locations of underground services are approximate only and their exact position should be proven on site. No guarantee is given that all existing services are shown.

DRAWN K. SCHULZE	CHECKED
DATE 1-9-1992	DATE
DESIGNED	CHECKED
DATE	DATE
DESIGN PROJECT LEADER	PROJECT OFFICER
DATE JULY 2004	DATE



Department of Construction and Infrastructure

STANDARD DRAWING
SIGNAL DETAILS
POLE FOUNDATION

FILE No.	ASSET No.	SHEET No. 1 OF 1	DRAWING No. CS1501 - 3	AMEND.	SHEET SIZE A3
----------	-----------	---------------------	---------------------------	--------	------------------